



IMPORTANT FOR FUTURE REFERENCE

Please complete this information and retain this manual for the life of the equipment:

Model #: _____

Serial #: _____

Date Purchased: _____

UK, MT

AUSTRALIA

**Service & Parts Manual
Covering
SLG Series**



FOR YOUR SAFETY

DO NOT store or use gasoline or other flammable vapors or liquids in the vicinity of this or any other appliance. Do not spray aerosols in the vicinity of this appliance while it is in operation.

WARNING

Improper installation, alteration, service or maintenance can cause property damage, injury or death. Read the installation, operating and maintenance instructions thoroughly before installing or servicing this equipment.

TO THE PURCHASER

Post, in a prominent location, the instructions to be followed in the event that an operator smells gas. Obtain this information from your local gas supplier.

WARNING

There is an open flame inside this appliance. The unit may get hot enough to set nearby materials on fire. Keep the area around the appliance free from combustibles.

WARNING

DO NOT supply the appliance with a gas that is not indicated on the data plate. If you need to convert the appliance to another type of fuel, contact your dealer.

WARNING

DO NOT use an open flame to check for gas leaks!

WARNING

If gas flow to appliance is interrupted, or pilots extinguish, wait 5 minutes before attempting to relight the pilot to allow any residual gas in appliance to dissipate.

WARNING

Ensure that the appliance can get enough air to keep the flame burning correctly. If the flame is starved for air, it can give off a dangerous carbon monoxide gas. Carbon monoxide is a clear odorless gas that can cause suffocation.

WARNING

Adequate means must be provided to limit the movement of this appliance without depending on the gas line connection. Single appliances equipped with legs must be stabilized by installing anchor straps. All appliances equipped with casters must be stabilized by installing restraining chains. If a flexible gas line is used, an additional restraining cable must be connected at all times when the appliance is in use.

WARNING

An appliance equipped with casters and a flexible gas line must be connected to the gas supply with a quick disconnect device. This quick disconnect must comply with AS4631 (Australia only). To limit the movement of the appliance without depending on the connector or quick disconnect, a restraining cable must also be installed.

WARNING

Installation of this appliance must be done by a qualified professional. This appliance should be inspected by a qualified professional on an annual basis to insure safe and proper operation.

WARNING

In Australia, this appliance must be installed in accordance with AS 5601 (current revision) or local codes, or National Codes as applicable.

WARNING

This appliance must be installed by a competent installer. Install only in a well-ventilated area. Read the instructions before operating this appliance.

WARNING

If the appliance has a power supply, it must be disconnected before servicing or cleaning this appliance.

WARNING

Do not attempt to move this appliance when the unit is at operating temperature. Serious personal injury could result if skin comes in contact with the hot surfaces.

WARNING

DO NOT sit or stand on this appliance. Serious injury could result from falling or contact with hot shortening/oil.

TABLE OF CONTENTS

1	Leg Installation and Leveling	2
1.1	Installation Clearances	2
1.2	Gas Connection.....	2
1.3	Gas Connection and Sealing Compound.....	3
1.4	Fuel Supply Line Leak and Pressure Testing	3
2	INITIAL ADJUSTMENTS	3
2.1	Pilot Flame Adjustment after gas valve replacement.....	3
2.2	Main Burner System Adjustment.....	4
3	Thermostat Calibration.....	4
3.1	Thermostat Calibration Check (Standard).....	4
3.2	For Gas Operated and Electric Thermostats refer to the following procedure.	5
4	Trouble Shooting.....	6
4.1	Testing the Thermocouple:.....	7
4.2	Testing the Radix wire:.....	7
4.3	Testing the Hi Limit:.....	7
4.4	Testing the Gas Valve:.....	7
5	SLG40 Exploded Parts Diagram.....	8
5.1	SLG40 Exploded Parts List	9
6	SLG100 Exploded Parts Diagram.....	10
6.1	SLG100 Exploded Parts List	11
7	SLG40 Gas Assembly Exploded AU & CE Diagram	12
7.1	SLG40 Gas Assembly Exploded AU & CE Parts	13
8	SLG100 Gas Supply Exploded AU & CE Diagram	14
8.1	SLG100 Gas Supply Exploded AU & CE Parts.....	15
9	TSTAT Assembly Exploded AU Diagram	16
9.1	TSTAT Assembly Exploded AU Parts	17

1 Leg Installation and Leveling

This appliance must be installed with legs; it cannot be curb mounted. Curb mounting will seriously inhibit this appliances ability to effect proper combustion.

WARNING

This appliance must be installed with the legs provided by the manufacturer.

WARNING

Do not install legs or perform leveling procedure when unit is in operation or full of cooking medium. Serious injury could result.

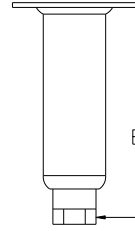

Required tools: 7/16 “ wrench and socket and a large pair of water pump pliers. The legs must be installed before connecting the appliance to the gas supply. The legs provide the necessary height to meet sanitation requirements and assure adequate air supply to the combustion system. Use the following procedure.

- a. Lay the appliance on its back, being careful not to damage the flue area by pulling on it. Protect the outside of the appliance with cardboard or a drop cloth when laying it down.
- b. Attach each leg with the hex head screws and nuts supplied. Each leg requires four ¼-20 x 5/8” hex head screws and nuts. Insure that all screws are tight.
- c. Mount the screws from the inside of the appliance with the nut on the outside (bottom) of the appliance. The nuts have lock washers attached to them, therefore it is not necessary to use lock washers
- d. When all four legs are securely mounted, stand the unit up, being careful not to put too much weight on any one leg. Adjust the height and level the appliance by adjusting the leveling devices (B) with water pump pliers.

1.1 Installation Clearances

The clearances shown below are for combustible and non-combustible installations and will allow for safe and proper operation of your appliance.

	Combustible Construction	Non-Combustible Construction
Back	6 in. (15 cm)	6 in. (15 cm)
Sides	6 in. (15 cm)	6 in. (15 cm)
Floor	N/A*	4 ¾ (11.5 cm)

*For use only on Non Combustible Floors. This appliance must be installed on a fireproof base.

In addition to the above clearances there must also be at least 28 inches (71 cm) of aisle space in front of the appliance.

1.2 Gas Connection

Your appliance will give you peak performance when the gas supply line is of sufficient size to provide the correct gas flow. The gas inlet of the appliance is located in the back of the appliance on the lower right hand side about 21 cm from the floor. The gas line must be installed in accordance with the requirements of AS 5601 or local codes, by a qualified professional. Gas line sizing requirements can be determined by a qualified installation professional, your local gas company or by the Technical Regulator. The gas line needs to be large enough to supply the necessary amount of fuel to all appliances without losing pressure to any appliance. A properly sized and installed gas line will deliver a minimum supply pressure of 7.0 ± 2.0 inches w.c. (1.75 ± 0.5 kPa/17.5± 5 mbar)) for natural gas and 12.0 ± 2.0 inches (3.0 ± 0.5 kPa/30± 5 mbar) for propane to all appliances connected to the supply line, operating simultaneously at full demand. Each appliance is equipped to operate on one certain fuel type. The type of fuel with which the appliance is intended to operate is stamped on the data plate, which is attached to the inside of the door.

1.3 Gas Connection and Sealing Compound

As with any gas appliance, be sure to use a suitable gas joint sealant whenever gas connections are loosened and retightened. Also remember to check for leaks before allowing the appliance to be put into service.

1.4 Fuel Supply Line Leak and Pressure Testing

The fuel supply system must be tested before the appliance is used. If the fuel line is going to be tested at a pressure greater than ½ PISG (3.45 kPa/34.5 mbar), insure that that appliance is disconnected from the fuel line. If the fuel line is to be tested at a pressure equal to or less than ½ PSIG (3.45 kPa/34.5 mbar), the appliance can be connected during the test, but the unit's gas valve must be shut. Test all gas line connections for leaks with a solution of soap and water when pressure is applied.

2 INITIAL ADJUSTMENTS

After the appliance has been properly installed as described in the installation section of this manual, it will need to be adjusted to ensure that it will perform as designed. These adjustments must be performed by a qualified person. To perform these adjustments the following tools will be needed:

- Manometer
- Digital Thermometer (Temperature Probe)
- DC Millivolt Meter
- DC Millimeter

Before you begin filling and adjusting the appliance, perform the following visual checks:

- After the appliance is in its permanent location, check the levelness. Any additional leveling that is necessary can be performed as previously described.
- Check the temperature probe and high limit bulb (in the tank) to ensure that the mounting screws are tight.
- Review the installation portion of this manual and ensure that all steps have been followed and executed properly.

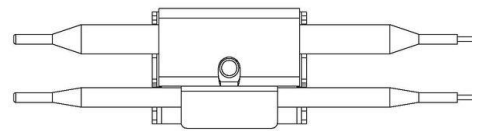

2.1 Pilot Flame Adjustment after gas valve replacement

For manual pilots, refer to the following instructions. Perform this procedure once the pilot is lit.

NOTE: This procedure requires a DC millivolt meter set to a scale of 0-1000 mV.

Using test leads with sharp probes will help in taking the required readings.

- Locate the thermocouple wires coming from the thermostat/limit box going to the gas valve. The wire size decreases near the gas valve connections.
- Using the positive (+) test probe, connect the probe to the high limit wire terminal. On UFM systems, pierce the high limit wire insulation, with the tip of the test lead probe, at the gas valve safety magnet connection.
- Connect the negative (-) test probe to the pilot tubing.
- Remove the cap screw located below the pilot tubing on the gas valve. The pilot flame adjustment screw is recessed behind this. Turning the pilot flame adjustment screw clockwise lowers the pilot flame and millivolt output. Turning the pilot flame adjustment screw counter-clockwise increases the pilot flame size and millivolt output.
- While monitoring the DC millivolt meter, rotate the pilot flame adjustment screw in the direction necessary to achieve a reading of $400 \pm 50\text{mV}$.
- Replace the cap screw.

Note: Allow 3 to 5 minutes between flame adjustments to allow the reading to stabilize.

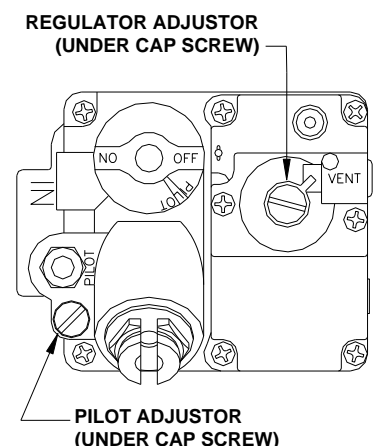

2.2 Main Burner System Adjustment

For the main burners to operate the gas supply valve must be open and the thermostat must be turned on. For models with electric controls, the main power switch must be on. The main burners receive gas from the main gas supply through the thermostatically controlled valve. When the thermostat is turned up to a setting higher than the temperature of the oil in the tank, the gas control valve opens.

The main burner pressure must be adjusted to deliver optimum flame. Refer to the following procedure to adjust the main burners.

CAUTION

Before proceeding any further, fill the tank with WATER. Water is used for the installation adjustments because the temperature will never exceed 212°F (100°C), thereby allowing plenty of adjustment time. Never let the water level go below the MIN LEVEL mark stamped on the tank.

- a. Ensure that the main gas valve is shut off; remove the manifold pressure tap plug and connect an accurate pressure gauge having a range from 0 to 16 " w.c. in 0.1" increments (0 to 4 kPa in .025 kPa/0-40 in 0.25 mbar increments) or manometer with similar resolution.
- b. Turn on this and all appliances connected to the gas supply line and light their main burners. The pressure reading of the installed pressure gauge should not drop from the required installation pressure. Any loss of pressure indicates inadequate supply line installation, which will cause poor performance of all appliances during peak usage.
- c. The installed pressure gauge should be the same, ± 0.1 " w.c. (.025 kPa/.250 mbar), as that marked on the data plate on the inside door of the appliance. If the pressure is correct, go to step e, if it is not, adjust the pressure as outlined in step d.
- d. To adjust the pressure, remove the regulator adjustment screw cap on the gas valve and, with a flat head screwdriver, adjust the regulator screw until the proper burner pressure is reached. Turning the screw clockwise will increase the burner pressure. Turning the screw counterclockwise will decrease the burner pressure.
- e. When the pressure is correct, replace the regulator adjustment screw cover.
- f. Turn off the ALL appliances, shut the main gas valve to your appliance and remove the pressure gauge. Apply pipe joint compound to the manifold pressure tap plug and reinstall it.

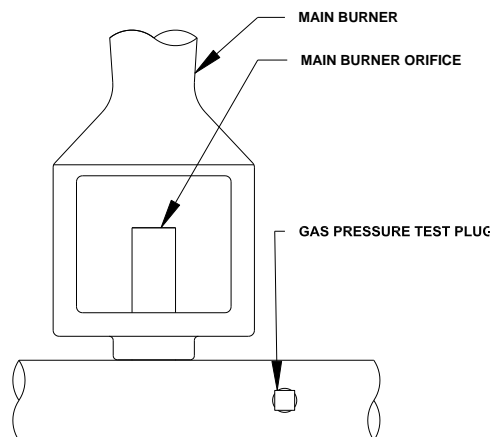

3 Thermostat Calibration

NOTICE

Thermostat calibration requires that the temperature of the appliance be raised above 212°F (100°C). If you have water in the tank you will need to drain it, dry it and fill it with shortening/oil. Follow the filling instructions in this manual.

3.1 Thermostat Calibration Check (Standard)

To check the calibration of your appliance, refer to the following procedure.

- a. Remove the tube screen from the tank.
- b. Place the tip of a digital thermometer probe in the shortening/oil approximately one inch above the temperature sensor.
- c. Light the pilot as described in this manual, set the thermostat to 325°F (163 °C) and allow the shortening/oil to come up to temperature. Watch the thermometer closely as the temperature rises.
- d. If the shortening/oil temperature reaches 350°F (177 °C) and the burners do not turn off, turn the thermostat down. Keep lowering the thermostat setting until the burners go out. Let the appliance cycle 4 to 6 times before checking the temperature. Compare the thermometer temperature against the thermostat setting. If the values are more than 5°F (3 °C) apart, calibrate the thermostat using procedure in this manual.

CAUTION

If the burners do not shut off at the **LOWEST** thermostat setting, the thermostat may be defective. Contact your local service company.

3.2 For Gas Operated and Electric Thermostats refer to the following procedure.

- a. Remove the tube screen from the tank and place the tip of a digital thermometer in the shortening/oil approximately one inch above the temperature sensor.
- b. Light the pilot as described in this manual, set the thermostat to 325°F (163 °C) and allow the shortening/oil to come up to temperature; let the appliance cycle 4-6 times to insure that the shortening/oil temperature has stabilized. Compare the thermostat setting of 325°F (163 °C) to the digital thermometer reading.
- c. Remove the thermostat dial by pulling the knob straight out. **DO NOT** rotate the dial.
- d. Holding the outside of the shaft so that it **DOES NOT MOVE**, scrape away the sealing compound in the center of the shaft with a small flat blade screwdriver.
- e. Turn the adjustment screw clockwise to lower the thermostat's temperature setting or counter-clockwise to raise it.

NOTE

One-quarter turn of the adjustment screw changes the temperature setting approximately 24°F (13 °C).

- f. Turn the adjustment screw until the burners come on at 325°F (163 °C).
- g. Replace the knob and allow the appliance to cycle 4 to 6 times. Check the temperature of the digital thermometer against the thermostat dial setting; if there is greater than a 5°F (3 °C) difference, repeat the calibration procedure.

4 Trouble Shooting

Refer to this section to correct common problems that may be encountered during the course of normal operation. If applicable, a schematic is provided behind the panel containing the electrical components.

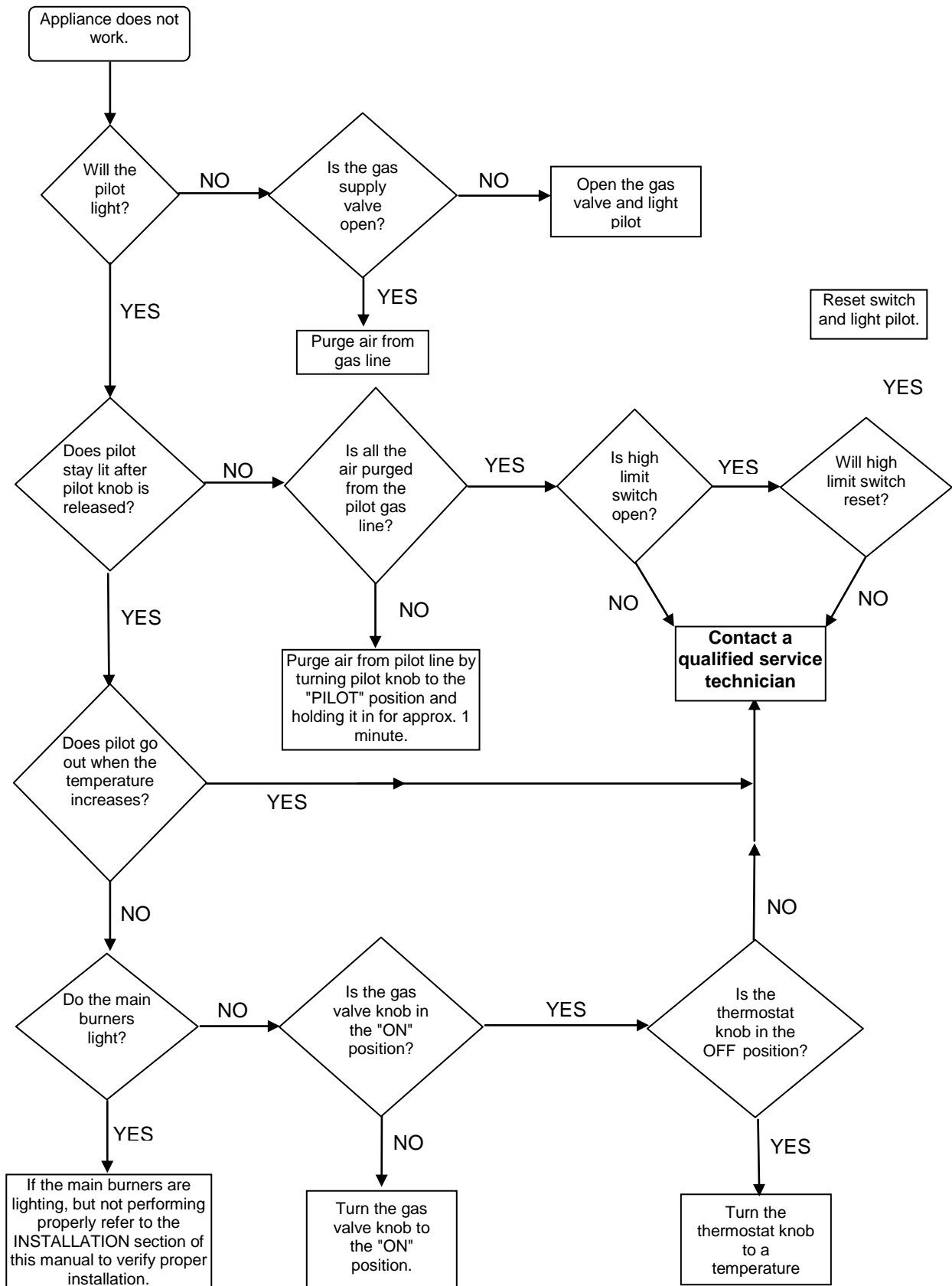

4.1 Testing the Thermocouple:

You will need a multimeter that can measure millivolts. Make sure that after holding a flame to the thermocouple it produces 30 mv. You can test for this by heating the thermocouple for about a minute and then place one lead on the copper casing of the thermocouple and the other lead on one of terminals of the hi limit wire connection. This is the easiest way to check the thermocouple but you are also going on the faith that the Radix wire and hi limit are good. If you do not get between 25 and 30 millivolts you need to replace this part, part number is P5047540.

Stay away from any hard or sharp bends in the thermocouple. It tends to separate the wire inside the copper casing. Another good tip is when screwing in the thermocouple always start by hand. You should get several turns out of it before needing a wrench. Cross threading will damage the aluminum threads for the magnet. After the thermocouple is finger tight give it a quarter turn with a wrench, no more. If all these parts check out and the pilot still wont stay lit you need to recheck everything something there is missing.

4.2 Testing the Radix wire:

Make sure that your Radix (gas valve to hi limit) wire isn't damaged or broken. The easiest is to remove the thermocouple from the valve, remove the Radix wire and inspect both sides of that butterfly connector. Make sure the wires aren't broken and then check for continuity through it. If it is bad the part number is B6779850.

4.3 Testing the Hi Limit:

Press the red reset button and make sure it doesn't click. If it does, push it until it doesn't. This means the unit overheated or the hi limit tripped early. To check the trip temp of the switch the fryer will need to be ran at a set temp of 400°F (204°C). The limit should trip at 450°F (232°C) plus or minus 25°F (14°C) degrees. Check for continuity through the posts to ensure that the switch is making contact. If it won't reset or it reads an open signal you have a bad hi limit, the part number is PP10084.

One factor to look for that won't show up as a bad part is a crack in the black plastic casing of the hi limit. This would cause a problem; it happens when the radix wire thermocouple is cross threaded or over tightened.

4.4 Testing the Gas Valve:

With the thermocouple and Radix wire removed, take one lead of a multimeter and place it into the center of the magnet of the valve. The magnet is the aluminum insert on the valve you screw the thermocouple into. There is a concave landing in the center of the insert. It is insulated from the rest of the valve. Place the other lead on the threaded part of the insert. Make sure the lead on the center landing doesn't touch anything else or you will get an incorrect reading. You're checking resistance, and you're looking for 8 to 11 ohms. If it's more or less you have a bad magnet inside the valve and the valve needs to be replaced.

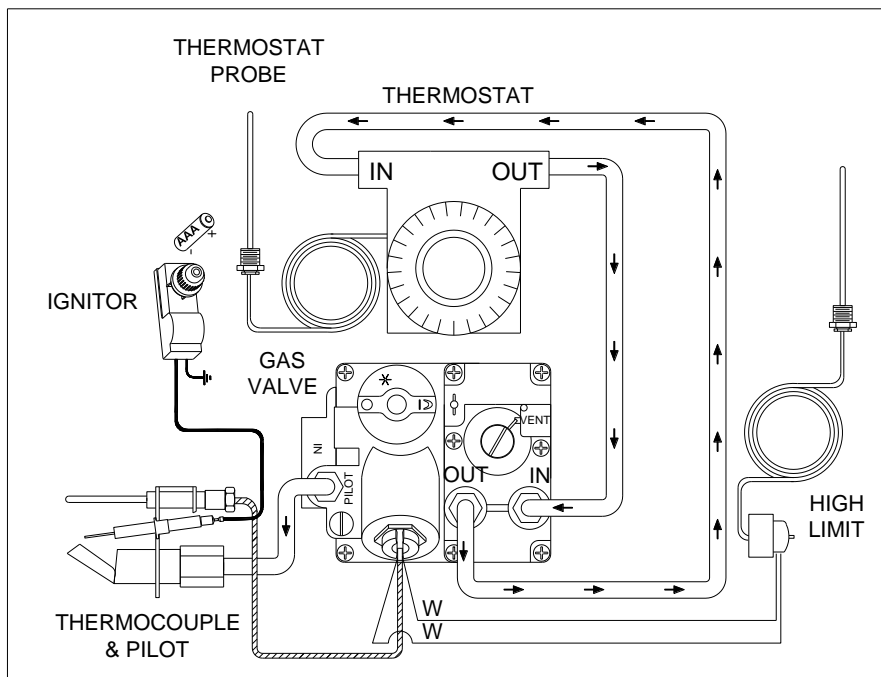

5 SLG40 Exploded Parts Diagram

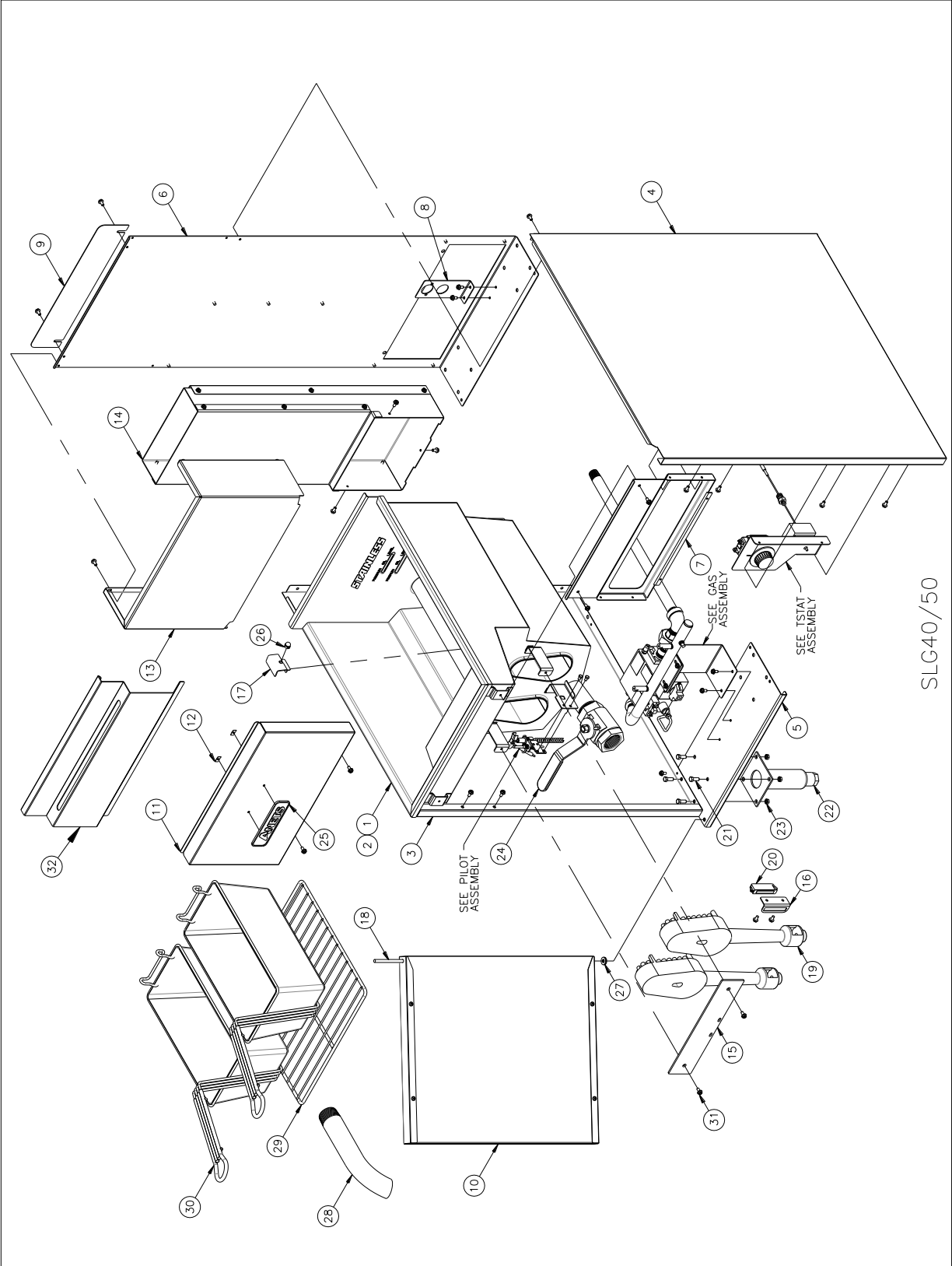

SLG40/50

5.1 SLG40 Exploded Parts List

ITEM#	PART#	PART DESCRIPTION
1	B3332601	TANK, WELDMENT SLG40 (BAFFLES WELDED TO TANK)
2	B1004001	BAFFLE, WELDMENT SLG40 (SERVICE)
3	A1540001	CABINET SIDE, LEFT HAND SLG40 BEFORE JULY 2013
	A1541101	CABINET SIDE, LEFT HAND SLG40 POST JULY 2013
4	A1540005	CABINET SIDE, LEFT HAND SLG40 BEFORE JULY 2013
	A1541103	CABINET SIDE, LEFT HAND SLG40 POST JULY 2013
5	A1237801	CABINET, FRONT BOTTOM BRACE SLG40 BEFORE JULY 2013
	A1861001	CABINET, FRONT BOTTOM BRACE SLG40 POST JULY 2013
6	A1640301	CABINET BACK, BOTTOM BRACE SLG40 BEFORE JULY 2013
	A1641401	CABINET BACK, BOTTOM BRACE SLG40 POST JULY 2013
7	A1856901	CABINET, SPACER SLG40 BEFORE JULY 2013
	A1861201	CABINET, SPACER SLG40 POST JULY 2013
8	A8048001	PIPING, BRACKET MANIFOLD REAR
9	B13811-00	FLUE, DEFLECTOR SLG40
10	B2306101	DOOR, ASSEMBLY SLG40 BEFORE JULY 2013
	B2306301	DOOR, ASSEMBLY SLG40 POST JULY 2013
	A2336502	DOOR, OUTER SLG40 BEFORE JULY 2013
	A2337302	DOOR, OUTER SLG40 POST JULY 2013
	A2336601	DOOR, INNER SLG40 BEFORE JULY 2013
	A2337401	DOOR, INNER SLG40 POST JULY 2013
	PP10752	SCREW, 10-31 X 1/2 PNH ZN
11	D6176-00	FRONT PANEL, SLG40 BEFORE JULY 2013
	A3684902	FRONT PANEL, SLG40 POST JULY 2013
12	P0091500	TINNERMAN C-12003-017 #6
13	D6180-00	SPLASH BACK, SLG40
14	C11020-00	FLUE, ASSEMBLY SLG40
	B3506401	FLUE, ASSEMBLY SLG50
15	B13790-00	BURNER HOLD DOWN SLG40
	A8048802	BURNER HOLD DOWN SLG50
16	A1847002	CLIP, BRACKET MAGNET CATCH
18	A1408002	BULB COVER STEPPED SLG
18	A3800603	DOOR HINGE PIN
19	E4556-04	BURNER
20	P6071300	DOOR MAGNET
21	P0020600	SCREW, 1/4-20 X 5/8 HEX HEAD ZINC PLATED
22	B3900701	LEG, SET 6" WITH HARDWARE (SET OF 4)
23	P0093300	NUT, HEX (KEP) 1/4-20 ZINC PLATED
24	60084501	DRAIN VALVE, 1 1/4 NON-LOCKING
25	P9204-75	ANETS NAME PLATE BLACK/YELLOW
26	PP10668	NUT, 1/4-20 ACORN WITH CENTERLOCK STAINLESS
27	P0080650	WASHER, FLAT 1/4 ZINC
28	A2510101	TANK, NIPPLE DRAIN OUT 1 1/4 NPT
29	A4500601	WIRING RACK, TUBE 13.50 X 13.50
30	P9800-08	BASKETS, DOUBLE 2 PER SLG40
31	PP10023	SCREW, 10-24 X 3/8 SELF TAPPER
32	C9054-01	BASKET HANGER SLG40/50

6 SLG100 Exploded Parts Diagram

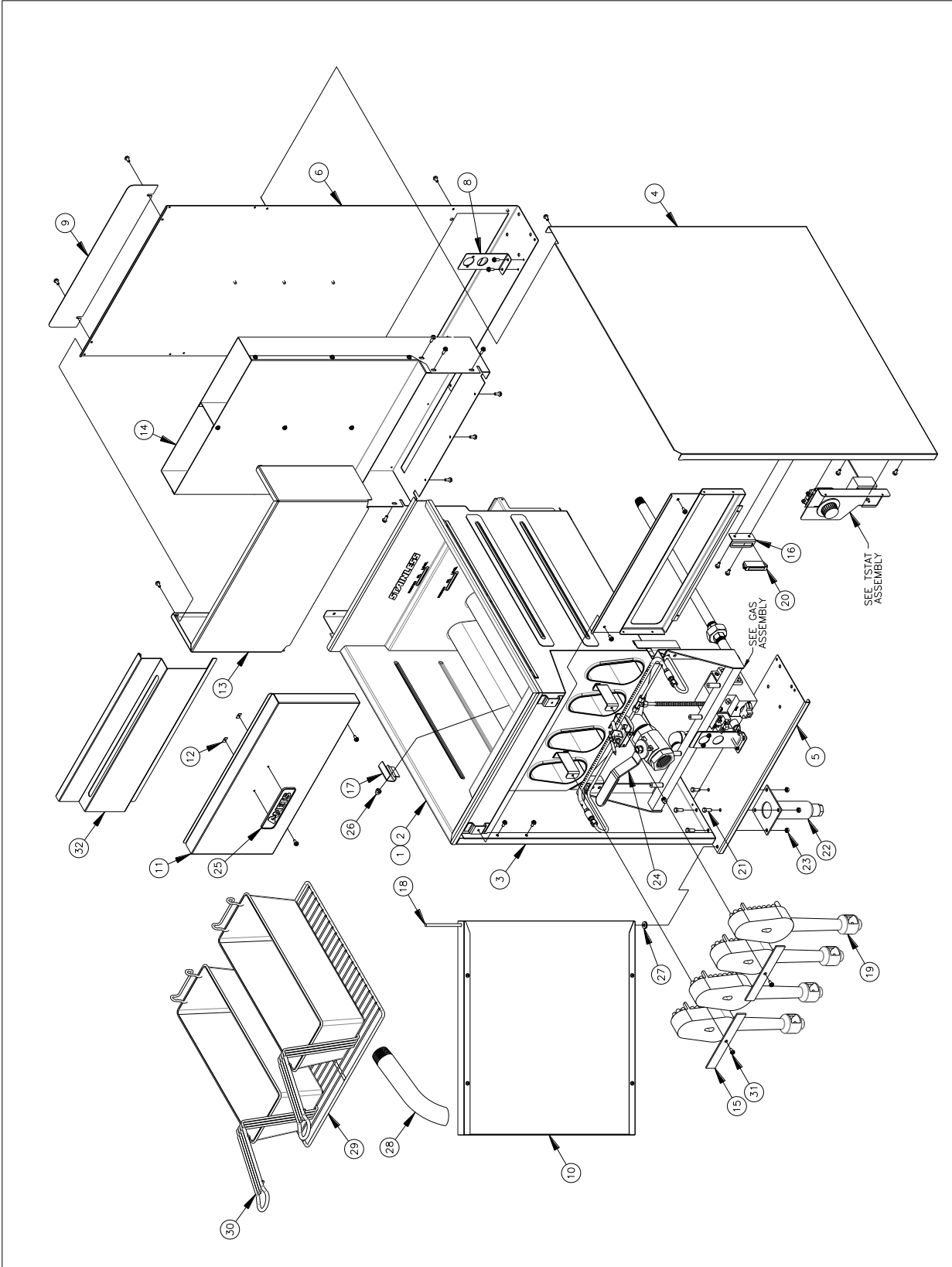

6.1 SLG100 Exploded Parts List

ITEM#	PART#	PART DESCRIPTION
1	B3336301	TANK,WELDMENT SLG100 (BAFFLES WELDED TO TANK)
2	B1004002	BAFFLE, WELDMENT SLG100 (SERVICE)
3	A1540003	CABINET SIDE, RIGHT SIDE SLG100 BEFORE JULY 2013
	A1541105	CABINET SIDE, RIGHT SIDE SLG100 POST JULY 2013
4	A1540007	CABINET SIDE, RIGHT SIDE SLG100 BEFORE JULY 2013
	A1541107	CABINET SIDE, RIGHT SIDE SLG100 POST JULY 2013
5	A1237803	CABINET, FRONT BOTTOM BRACE SLG100 BEFORE JULY 2013
	A1861003	CABINET, FRONT BOTTOM BRACE SLG100 POST JULY 2013
6	A1640303	CABINET BACK, BOTTOM BRACE SLG100 BEFORE JULY 2013
	A1641403	CABINET BACK, BOTTOM BRACE SLG100 POST JULY 2013
	A1857001	CABINET, SPACER SLG100 BEFORE JULY 2013
	A1861203	CABINET, SPACER SLG100 POST JULY 2013
8	A8048001	PIPING, BRACKET MANIFOLD REAR
9	B14090-00	FLUE, DEFLECTOR SLG100
10	B2306102	DOOR, ASSEMBLY SLG100 BEFORE JULY 2013
	B2306302	DOOR, ASSEMBLY SLG100 POST JULY 2013
	A3636504	DOOR, OUTER SLG100 BEFORE JULY 2013
	A2337304	DOOR, OUTER SLG100 POST JULY 2013
	A2336603	DOOR, INNER SLG100 BEFORE JULY 2013
	A2337403	DOOR, INNER SLG100 POST JULY 2013
	PP10752	SCREW, 10-31 X 1/2 PNH ZN
11	PP11006	HANDLE, DOOR RECESSED PLASTIC
	A3681802	FRONT PANEL, SLG100 BEFORE JULY 2013
	A3684904	FRONT PANEL, SLG100 POST JULY 2013
12	P0091500	TINNERMAN C-12003-017 #6
13	E5192-00	SPLASH BACK, SLG100
14	C10880-00	FLUE, ASSEMBLY SLG100
	E5190-00	FLUE BACK
	D6265-00	FLUE FRONT
	C10860-00	FLUE SUPPORT
15	B14052-00	BURNER HOLD DOWN SLG100
16	A1847002	CLIP, BRACKET MAGNET CATCH
18	A1408002	BULB COVER STEPPED SLG
18	A3800603	DOOR HINGE PIN
19	E4556-04	BURNER
20	P6071300	DOOR MAGNET
21	P0020600	SCREW, 1/4-20 X 5/8 HEAX HEAD ZINC PLATED
22	B3900701	LEG, SET 6" WITH HARDWARE (SET OF 4)
23	P0093300	NUT, HEX (KEP) 1/4-20 ZINC PLATED
24	60084501	DRAIN VALVE, 1 1/4 NON-LOCKING
25	P9204-75	ANETS NAME PLATE BLACK/YELLOW
26	PP10668	NUT, 1/4-20 ACORN WITH CENTERLOCK STAINLESS
27	P0080650	WASHER, FLAT 1/4 ZINC
28	A2510101	TANK, NIPPLE DRAIN OUT 1 1/4 NPT
29	P6073186	TUBE RACK
30	P9800-48	BASKET
	P9800-56	TRIPLE BASKET
31	PP10023	SCREW, 10-24 X 3/8 SELF TAPPER
32	C9183-00	BASKET HANGER SLG100

7 SLG40 Gas Assembly Exploded AU & CE Diagram

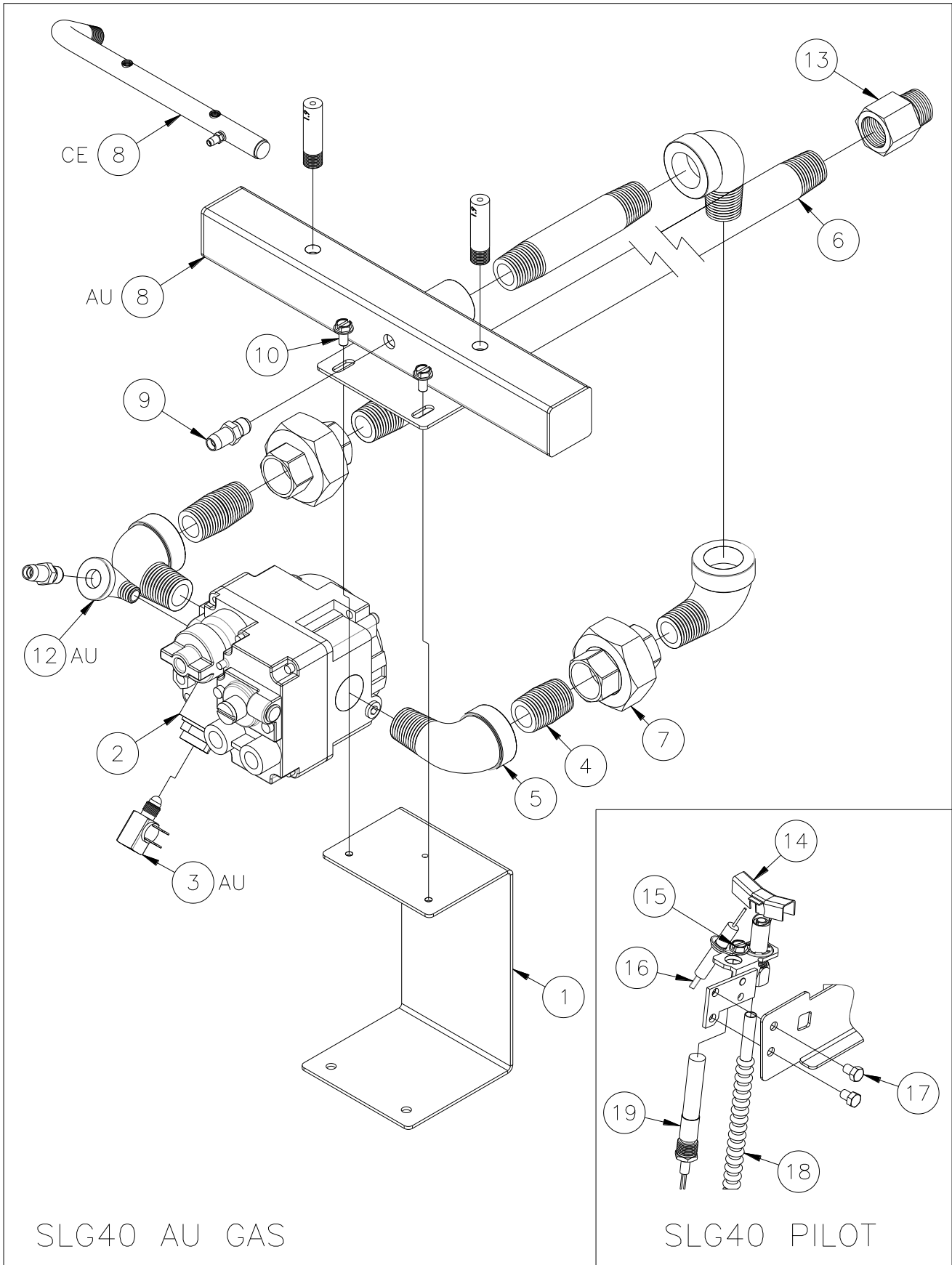

7.1 SLG40 Gas Assembly Exploded AU & CE Parts

ITEM#	PART#	PART DESCRIPTION
1	A8049901	PIPING, MANIFOLD BRACKET FRONT SLG40
2	PP11001	GAS VALVE G20 U7000 SLG40
	PP11002	GAS VALVE G31 U7000 SLG40
	PP11110	GAS VALVE G20 BGOL/S UNREGULATED
3	60179801	INTERRUPTOR,MV 11/32 THREAD
4	P7037090	NIPPLE, BLACK 1/2 NPT X CLOSE
5	P7037750	ELBOW, STREET 1/2 NPT 90 DEGREE
6	P8820-91	NIPPLE, BLACK 1/2 NPT X 17"
7	P7036902	UNION BLACK 1/2 NPT
8	B8058801	PIPING, WELDMENT GAS MANIFOLD AU
	P8841-38	PIPING, WELDMENT GAS MANIFOLD CE
9	60132801	PRESSURE TEST FITTING 1/8 NPT
10	PP10023	SCREW, 10-24 X 3/8 SELF TAPPER
11A	P8905-04	ORIFICE, BURNER #31 NAT/G20 SLG40
	A8047103	ORIFICE, BURNER 1.9mm PROPANE SLG40
	P8905-16	ORIFICE, BLANK
		ELEVATION CHANGE
11B	P8905-83	ORIFICE, BURNER #34 NATURAL
	A8047101	ORIFICE, BURNER 3.4mm NATURAL G25
	A8047104	ORIFICE, BURNER #35 NATURAL
	A8047105	ORIFICE, BURNER #36 NATURAL
	A8047106	ORIFICE, BURNER #37 NATURAL
	A8047107	ORIFICE, BURNER #38 NATURAL
	A8047108	ORIFICE, BURNER #39 NATURAL
	A8047110	ORIFICE, BURNER #33 NATURAL
	P8905-84	ORIFICE, BURNER #50 PROPANE
	A8047102	ORIFICE, BURNER #51 PROPANE
	A8047103	ORIFICE, BURNER 1.9mm PROPANE G31
A8047109	ORIFICE, BURNER #52 PROPANE	
12	60094101	BRASS STREET ELBOW 1/8 NPT
13	PP10067	METRIC GAS SUPPLY ADAPTER FITTING
14	60128801	PILOT REVERSE STANDING NAT
	60128802	PILOT REVERSE STANDING LP
15	P0075200	SELF DRILLING SCREW 8-18 X 1/2
16	P9131-55	GAS VALVE VENT TUBE (DOMESTIC ONLY)
17	60088014	NIPPLE, BLACK 1/2 NPT X 2"
18	60119001	ELBOW, STREET 1/2 NPT 90 DEGREE
19	60125501	NIPPLE, BLACK 1/2 NPT X 17"

8 SLG100 Gas Supply Exploded AU & CE Diagram

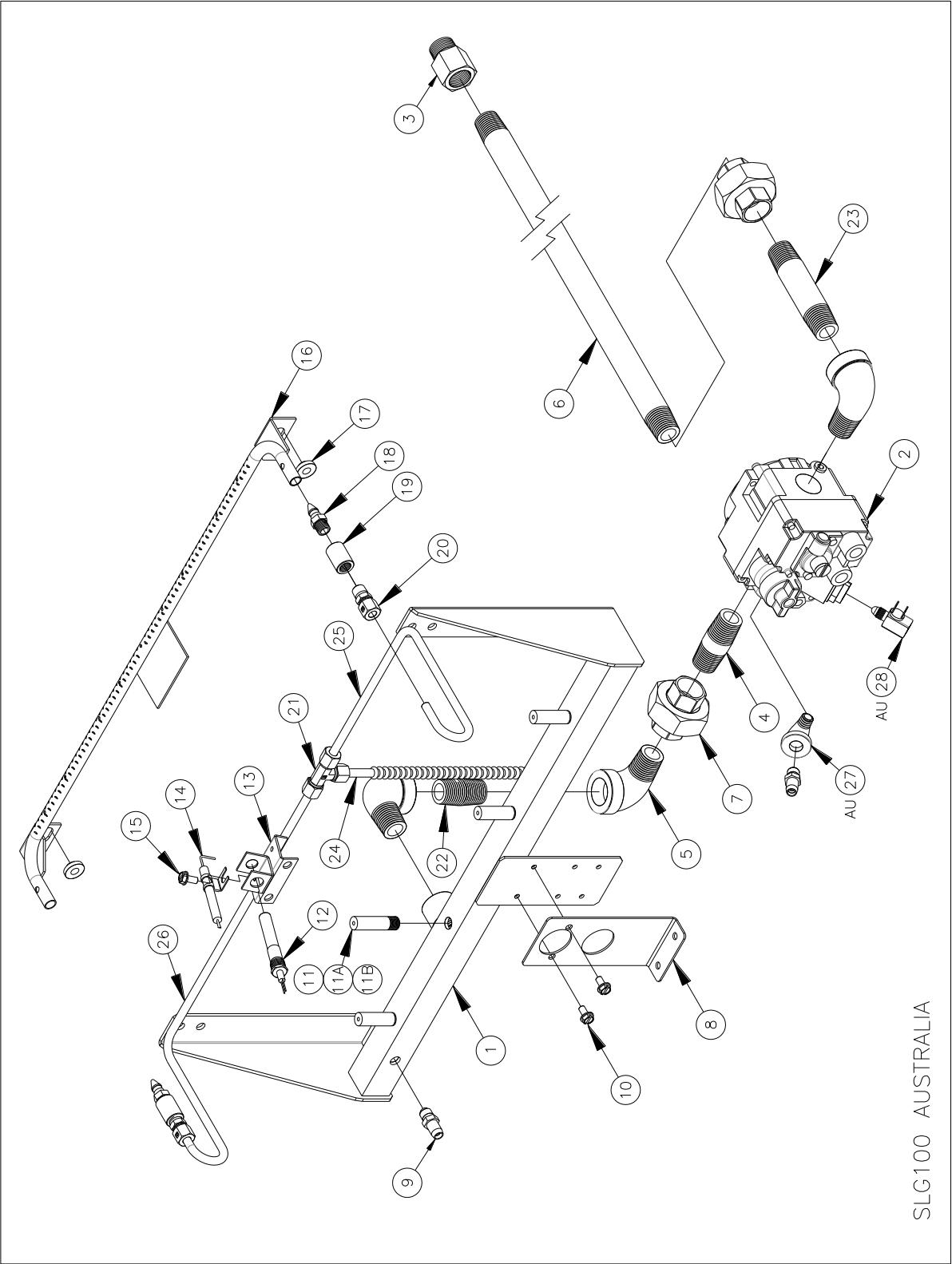

SLG100 AUSTRALIA

8.1 SLG100 Gas Supply Exploded AU & CE Parts

PLOT	PART#	PART DESCRIPTION
1	P9315-61	PIPING, WELDMENT GAS MANIFOLD SLG100
2	PP10955	GAS VALVE G20/G25 U7000
	PP10956	GAS VALVE G31 U7000
	PP11110	GAS VALVE G20 BGOL/S UNREGULATED
3	PP10067	GAS SUPPLY METRIC ADAPTER
4	P7037093	NIPPLE, BLACK 1/2 NPT X 2"
5	P7037750	ELBOW, STREET 1/2 NPT 90 DEGREE
6	P8820-91	NIPPLE, BLACK 1/2 NPT X 17"
7	P7036902	UNION BLACK 1/2 NPT
8	A8048001	GAS SUPPLY WELDMENT SUPPORT BRACKET SLG100
9	60132801	GAS MANIFOLD TEST FITTING 1/8 NPT
10	PP10023	SCREW, 10-24 X 3/8 SELF TAPPER
11	P8905-04	ORIFICE, BURNER #31 NATURAL SLG100
	P8905-05	ORIFICE, BURNER #49 PROPANE SLG100
11A	P8905-16	ORIFICE, BLANK
		ELEVATION CHANGE OR CE ORIFICE TIPS
11B	P8905-83	ORIFICE, BURNER #34 NATURAL
	A8047101	ORIFICE, BURNER 3.4mm NATURAL
	A8047104	ORIFICE, BURNER #35 NATURAL
	A8047105	ORIFICE, BURNER #36 NATURAL
	A8047106	ORIFICE, BURNER #37 NATURAL
	A8047107	ORIFICE, BURNER #38 NATURAL
	A8047108	ORIFICE, BURNER #39 NATURAL
	A8047110	ORIFICE, BURNER #33 NATURAL
	P8905-84	ORIFICE, BURNER #50 PROPANE
	A8047102	ORIFICE, BURNER #51 PROPANE
	A8047103	ORIFICE, BURNER 1.9mm PROPANE
	A8047109	ORIFICE, BURNER #52 PROPANE
12	60125501	THERMOPILE MILLIVOLT
13	B12326-00	THERMOPILE SUPPORT WELDMENT
14	P9131-62	SPARK IGNITOR
15	P0075300	SELF DRILLER 10/16 X 5/8
16	C9163-00	PILOT RUNNER TUBE WELDMENT NAT SLG100
	C9163-01	PILOT RUNNER TUBE WELDMENT LP SLG100
17	B12821-00	PILOT STANDOFF SPACER
18	P8904-98	RUNNER TUBE ORIFICE NAT #55 SLGOO
	P9804-99	RUNNER TUBE ORIFICE LP #72 SLGOO
19	P8805-11	COUPLING 1/8 NPT
20	P7037797	ELBOW 1/4 COMPRESSION X 1/8 NPT
21	P8840-92	COMPRESSION TEE 1/4 TUBE
22	P7037092	NIPPLE, BLACK 1/2 NPT X 1 1/2
23	P7037096	NIPPLE, BLACK 1/2 NPT X 3 1/2
24	PP11260	FLEXIBLE TUBE 1/4 X 10
25	P9315-61	FLEXIBLE TUBE 1/4 X 12
26	60119001	FLEXIBLE TUBE 1/4 X 18
27	60094101	BRASS STREET ELBOW 1/8 NPT
28	PP10067	METRIC GAS SUPPLY ADAPTER FITTING

9 TSTAT Assembly Exploded AU Diagram

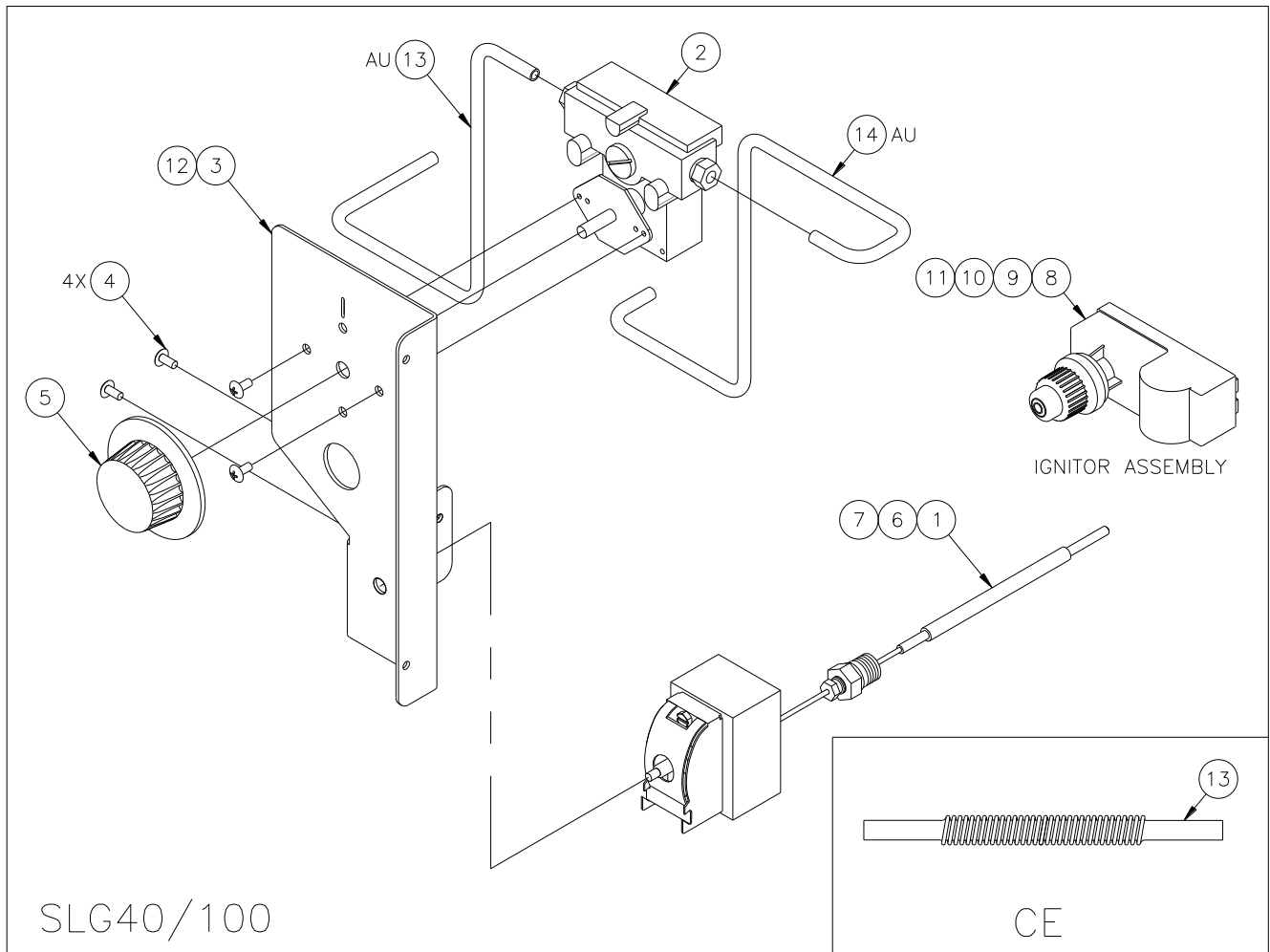

9.1 TSTAT Assembly Exploded AU Parts

ITEM#	PART#	PART DESCRIPTION
1	PP10084	SWITCH, HI-LIMIT
2	P5047590	THERMOSTAT, GS 190C
3	B14503-00	PIPING, BRACKET THERMOSTAT WITH IGNITOR
4	PP10687	SCREW, 6-32 X 5/16 TH PHILLIPS
5	PP10539	KNOB, THERMOSTAT
6	P0007300	SCREW, 8-32 X 1/4 HEX HEAD ZINC
7	B6744402	WIRING, MILLIVOLT HI-LIMIT/THERMOSTAT
8	P9132-34	CONTROL, SPARK IGNITOR
9	60172101	BATTERY, TRIPLE A 1.5V
10	60167801	CONTROL, WIRE SPARK IGNITOR 24"
11	P9132-37	CONTROL, SPARK IGNITOR GROUND WIRE
12	P9204-18	LABEL, IGNITOR
13	60119001	FLEX TUBING 18" CE
	A8049701	PIPING, THERMOSTAT IN-GAS VALVE-OUT SLG40 AU
	A8049703	PIPING, THERMOSTAT IN-GAS VALVE-OUT SLG100 AU
14	A8049702	PIPING, THERMOSTAT OUT-GAS VALVE-IN SLG40 AU
	A8049704	PIPING, THERMOSTAT OUT-GAS VALVE-IN SLG100 AU

In the event of problems with or questions about your order, please contact the Anetsberger Factory at:

+001 (603) 225-6684 (World Wide)

In the event of problems with or questions about your equipment, please contact the Anetsberger Authorized Service and Parts representative (ASAP) covering your area, or contact Anetsberger at the number listed to the left.

MAILING ADDRESS – P.O. BOX 501, CONCORD, NH 03302-0501
SHIPPING ADDRESS – 10 FERRY ST., CONCORD, NH 03301